

# UNIVERSAL SPA PUMP BRACKET AND COVER ASSEMBLY

GALVANISED STEEL CONSTRUCTION

EASY INSTALLATION, PRE-DRILLED FOR LEFT OR RIGHT HAND OUTLET

FITS MOST BRANDS OF PUMPS

PROVIDE PROTECTION FROM THE EXTREMES OF WEATHER

COMPONENTS CAN BE PURCHASED INDIVIDUALLY

AVAILABLE FROM LEADING PLUMBING SUPPLIES MERCHANTS ACROSS AUSTRALIA

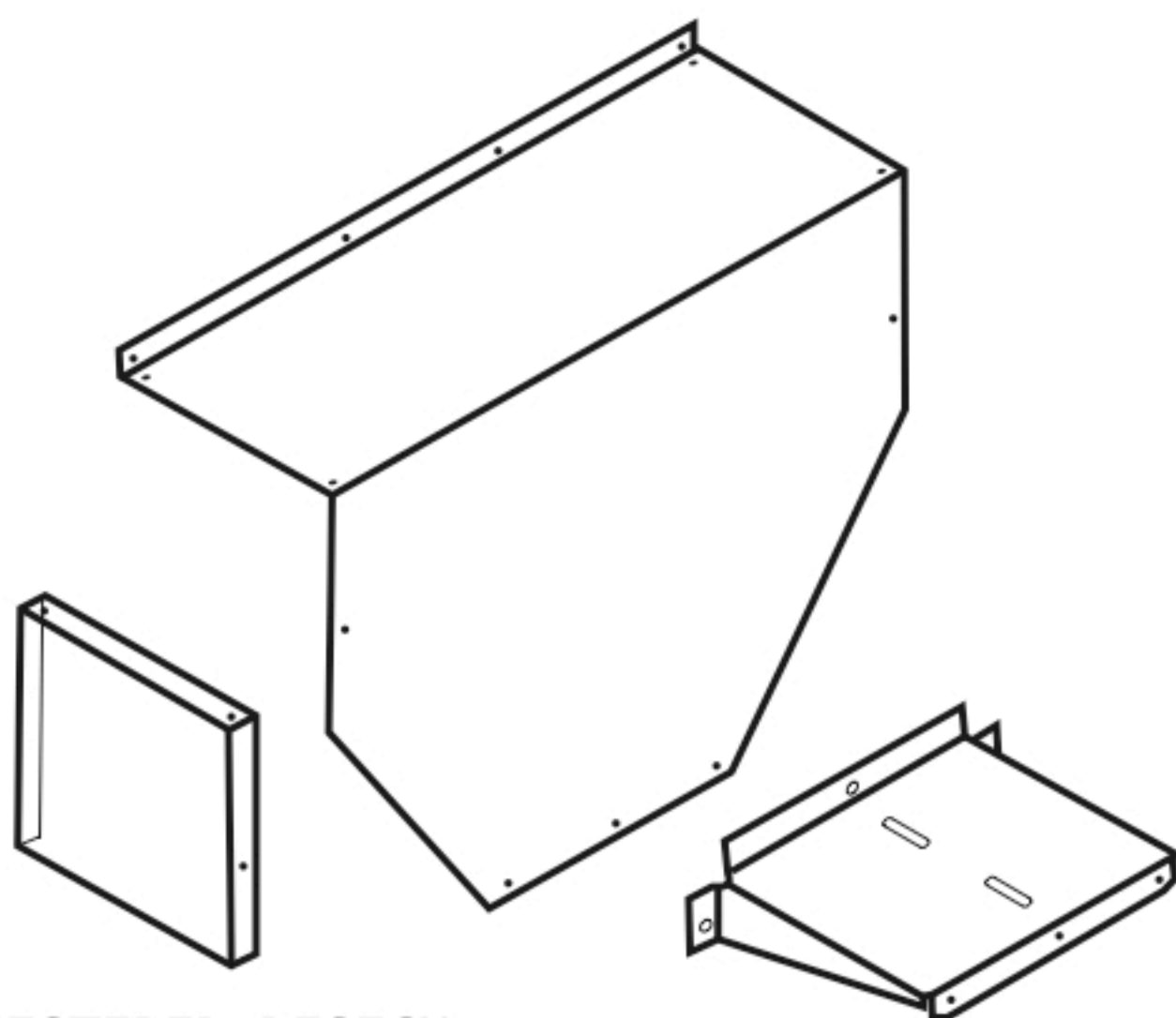
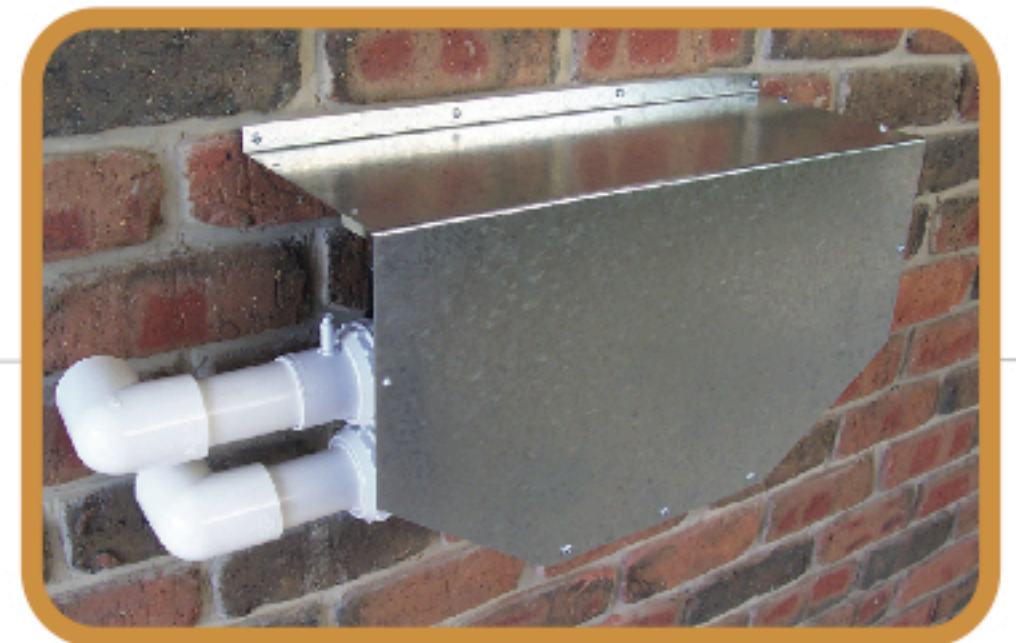

REGISTERED DESIGN

FASTENERS TO SECURE PUMP TO BRACKET AND COVERS SUPPLIED

POWDER COATED BRACKETS AND COVERS AVAILABLE

MANUFACTURED BY: W BROWN ENGINEERING & MAINTENANCE - SA